



PCS-9611

Feeder Relay

The PCS-9611 relay is a protection, control and monitoring unit for various applications (such as overhead line, underground cable and transformer etc.) on solidly grounded, impedance grounded, Peterson coil grounded and ungrounded system. The PCS-9611 features a high performance functional library, programmable logic, configurable I/O and integrated frequency-tracking.

The PCS-9611 is designed based on advanced multiprocessor platform, fully complying with IEC 61850 station bus & process bus, supporting IEC 61850-8-1 MMS, GOOSE and IEC 61850-9-2 Sampling Value.

Functions

Protection and Control

- Six-stage overcurrent protection. (67P, 50P/51P)
Phase overcurrent protection can be controlled by voltage control element, directional element and harmonic blocking element. IDMT curves complied with IEC and ANSI standard are provided.
- Six-stage neutral/ground overcurrent protection. (67G, 50/51G)
Up to two groups of neutral (ground) overcurrent protections are provided. It can be controlled by harmonic blocking element and directional element. IDMT curves complied with IEC and ANSI standard are provided.

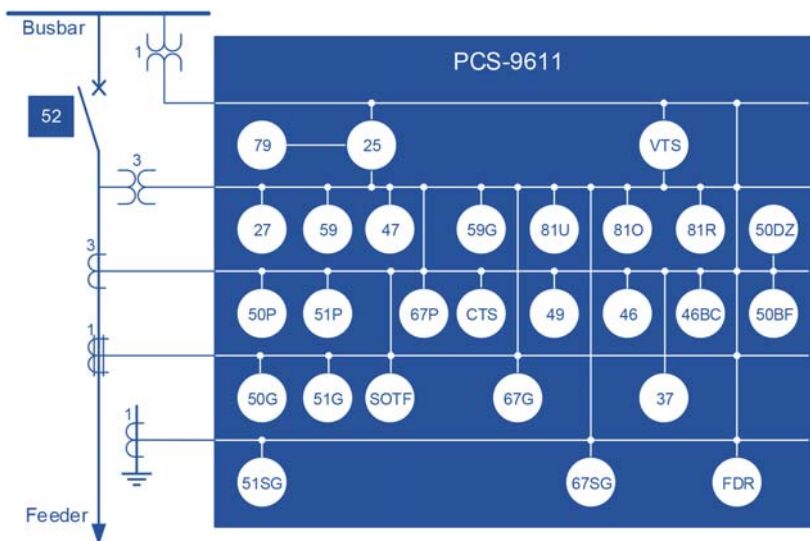

Figure 1 PCS-9611 Functional Block Diagram

- Four-stage sensitive earth fault protection. (67SG/51SG)
The sensitive earth fault protection can be controlled by directional element. IDMT curves complied with IEC and ANSI are provided.
- Two-stage undervoltage protection and two-stage over voltage protection. (27/59)
The voltage input can select either phase voltage or phase-to-phase voltage. VT failure blocking is integrated in this protection.
- One-stage negative sequence overvoltage protection. (47)
Negative sequence overvoltage protection could be used to detect the unbalance situation.
- Two-stage zero sequence overvoltage protection. (59G)
Zero sequence voltage could be set as external voltage injection or internal calculated voltage.
- Four-stage under-frequency protection, four-stage over-frequency protection and four-stage rate-of-change of frequency (81)
The rate-of-change of frequency could be set as increasing or decreasing via the setting, as well the duration used for rate-of-change calculation is settable.
- Breaker failure protection. (50BF)
The relay will initiate re-tripping and adjacent breaker tripping during breaker failure. Four logics based on the phase current and the circuit breaker state is selectable.
- 4-shot three-pole auto-reclosing with sync-check and dead line/bus check. (79/25)
Synchronism check and dead line/bus check are both provided for auto-reclosing.
- Dead zone protection. (50DZ)
Dead zone protection can operate when a fault occurs between CT and circuit breaker.
- Negative sequence overcurrent protection (46)
Two-stage negative sequence overcurrent protection IDMT curves complied with IEC and ANSI are provided.
- Broken conductor detection. (46BC)
The ratio of negative-sequence current to positive-sequence current (I_2/I_1) is used to detect the broken conductor.
- Thermal overload element. (49)
This relay provides a thermal overload model using the RMS value of current.
- Undercurrent protection. (37)
One-stage undercurrent protection is for monitoring a motor or a capacitor.
- Switch-onto-fault (SOTF) logic.
Switch-onto-fault logic is used to clear fault during manually closing or auto-reclosing.
- Cold load pickup logic (CLP)
The logic is used to inhibit the selected protective elements for an appointed duration, or to increase the settings of the selected protective elements.
- Mechanical Protection
Up to 4 channels for mechanical protection are provided. It receives the mechanical inputs from a transformer tank and issues the tripping or alarm outputs with or without time delay.
- Interlocking logic for distribution busbar protection.
The protection of distribution busbar can be realized via GOOSE communication.
- Remote and local tripping/closing of the breaker.
The breaker tripping/closing can be implemented remotely or locally.
- Interlocking logic of the breaker control.
The interlocking logic of the breaker, isolator and earth switch is integrated.
- Voltage and current drift auto adjustment.
The relay will continually and automatically trace the voltage and current drift and adjust the zero point to a normal value.
- Frequency tracking.
Frequency tracking is integrated to accommodate the frequency shift in power system.
- Fault locator.
The relay has an integral fault locator that uses information from the current and voltage inputs to provide a distance to fault location feature.

Monitoring and Metering

- Metering of current, voltage, active power, reactive power, power factor, energy, frequency, and harmonic.
- Circuit breaker monitoring.
- CT failure supervision.
- VT failure supervision.
- Line voltage failure supervision.
- Tripping circuit supervision.
- Self diagnostic.
- Fault Recorder.
- Total 1024 SOE, including tripping, alarm, binary input change and human operation reports.
- Total 64 oscillograms. (Compatible with COMTRADE format)

Communications

- Up to four 10Base-T/100Base-TX (RJ45) ports or two 100Base-FX ports with IEC 61850-8-1 MMS and GOOSE for

non-time-critical message, IEC 60870-5-103 over TCP/IP or DNP 3.0

- Two RS-485 rear ports with IEC 60870-5-103
- Up to Six 100Base-FX ports with IEC 61850-9-2 Sampling Value and GOOSE for time-critical message
- One RS-485 rear port for clock synchronization
- One RS-232 rear port for printer
- 1 faceplate RJ45 port for testing and setting
- Clock synchronization via pulse per second, IRIG-B and
- SNTP

Features

- Modularized hardware design enables an easy upgrade or repairs. Various optional function modules can satisfy various situations according to the different requirements of users.
- This device can sample the analog values from the conventional CT/VT, or receive the sampled values from electronic CT/VT via merging unit.
- Overcurrent protection can be controlled by directional protection, harmonic blocking element and voltage control element.
- The relay provides optional RTD input module and DC mA input module for temperature detection.
- This device constantly measures and calculates a large amount of analog quantities, such as phase voltage, phase-to-phase voltage, neutral voltage, phase current, neutral current, active power, reactive power, power factor and frequency etc.
- The connector type can be selected as plug in/out terminal connector or screw terminal connector. The unique plug in/ out terminal connectors from the relay rear panel to the terminal blocks on the rack or cabinet makes the onsite commissioning and replacement much easier than the traditional screw terminals when you do the commissioning.
- Various methods of GPS time synchronization are supported in this relay, including SNTP, pulse per second (PPS) and IRIG-B synchronization.
- This device can communicate with a SAS or RTU via different communication intermediates: Ethernet network, RS-485 serial ports. The communication protocol of this device is optional: IEC61850, IEC60870-5-103 or DNP3.0.
- This device can detect the tripping circuit of the circuit breaker and monitor the operation (close or trip) time of a circuit breaker by checking the auxiliary contacts of the circuit breaker.
- Complete event recording function is provided: 64 latest protection operation reports, 1024 latest supervision records, 1024 latest control operation records, 1024 latest user operation records and 1024 latest records of time tagged sequence of event (SOE) can be recorded.
- The relay is compatible with multiple protocols- IEC61850 and IEC 60870-5-103 for station bus, GOOSE and IEC61850-9-2 for process bus.
- The setting group can be switched by binary inputs.